

400 Series SLIM Specifications and Dimensions

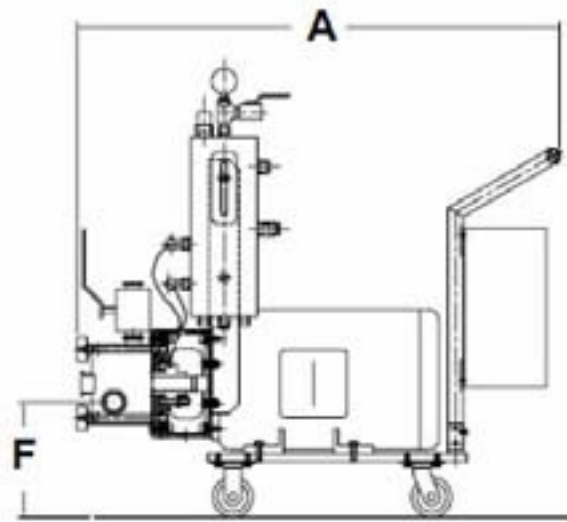
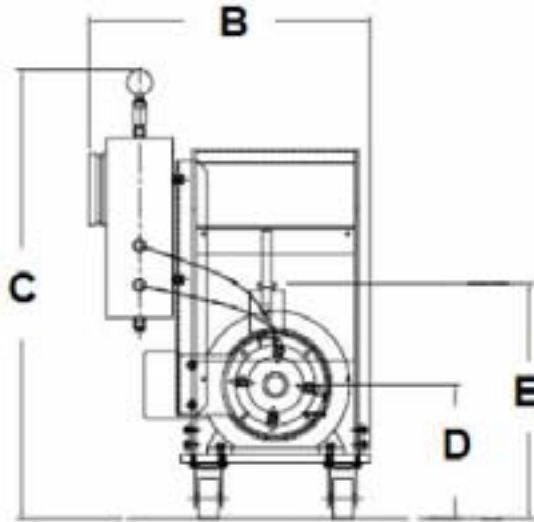

STANDARD FEATURES:

- Explosion proof motor designed for 230/460 volt, 3 phase, 50/60 Hz
- Slotted single stage rotor/stator with special SLIM induction rotor
- Double mechanical seal with Viton elastomers and barrier system
- Stainless Steel type 316 wetted parts with 150 grit polish
- Stainless Steel type 304 cart with caster wheels for easy movement of mixer except for 450SC which is on leveling pads and fork lift tubes for movement
- All non-Stainless Steel external surfaces coated with a white two-part epoxy paint

AVAILABLE OPTIONS:

- Hose & Wand available in a addition to or in lieu of funnel
- Special elastomers including Kalrez
- Various inlet, outlet and SLIM connections in lieu of Tri-Clover such as ANSI flange
- Large inlet connection, 3" in lieu of 2"
- Harder materials for the rotor such as Stainless Steel type 440C or Stellite tipped rotor
- Special motors including Stainless Steel, wash-down and various voltages and frequencies
- Controls including variable frequency drives, explosion proof operator stations and Human Machine Interfaces

Model	HP	Rotor		Connection Size			Overall Dimensions			Distance From Ground			Weight	Flow Rate (Water)
		RPM	Diameter	Inlet	SLIM	Outlet	Length (A)	Width (B)	Height (C)	Inlet (D)	SLIM (E)	Outlet (F)		
401SC-15	15	3,600	2.5"	1.5"	1"	1.5"	44.2"	25.5"	36.9"	11.9"	22.1"	9.7"	750 lbs	90 gpm
			63.5 mm	38.1 mm	25.4 mm	38.1 mm	1,123 mm	648 mm	937 mm	302 mm	561 mm	246 mm	340 kg	340 lpm
405SC-25	25	3,600	3.5"	2"	1.5"	2"	50.2"	27"	45"	13.4"	23.5"	11.4"	900 lbs	330 gpm
			88.9 mm	50.8 mm	38.1 mm	50.8 mm	1,275 mm	686 mm	1,143 mm	340 mm	597 mm	290 mm	408 kg	1,250 lpm
430SC	30	1,800	7"	3"	2.5"	3"	53.5"	30.7"	45"	13.5"	29.3"	8.2"	1,200 lbs	800 gpm
			177.8 mm	76.2 mm	63.5 mm	76.2 mm	1,359 mm	780 mm	1,143 mm	343 mm	744 mm	208 mm	544 kg	1,893 lpm
450SC	50	1,200	10.5"	4"	3"	4"	58"	31"	35"	13.5"	34.1"	6"	2,100 lbs	1,600 gpm
			267 mm	101.6 mm	76.2 mm	101.6 mm	1,473 mm	787 mm	889 mm	343 mm	866 mm	155 mm	953 kg	6,057 lpm



CHARLES ROSS & SON COMPANY

P.O. Box 12308, 710 Old Willets Path, Hauppauge, NY 11788

• Telephone: 631-234-0500 • Fax: 631-234-0691

• Website: www.mixers.com • Email: sales@mixers.com